

Time and Data Distribution Systems at the Fermilab Accelerator¹

David G. Beechy and Robert J. Ducar

Fermi National Accelerator Laboratory *

Batavia, Illinois 60510

ABSTRACT

The operation of the Fermilab accelerator has become increasingly complex over the last several years with the commissioning of the Tevatron and P-Bar Source. Four special purpose communication links have been developed to broadcast time, beam synchronization, and machine data.

These links have greatly facilitated the multi-mode operation of the accelerator complex. The most sophisticated of these links is the Tevatron Clock (TCLK). Up to 256 unique events may be encoded onto TCLK with typical resolution of 100 nanoseconds. 123 events have been assigned to date. Beam Sync clocks have been implemented for both the Main Ring and Tevatron. These clocks operate at approximately 7.5 MHz and are derived from the Main Ring and Tevatron RF systems. Beam diagnostics, beam transfers between machines, and placement of colliding proton and p-bar bunches are coordinated by encoded events on these clocks. A custom integrated circuit was designed to accommodate detection of the serially encoded events present on both Tevatron and Beam Sync clocks with a minimum of circuit overhead. The final link, MDAT, broadcasts machine data -most notably the value of bending current for both the Main Ring and Tevatron. Each of these links is distributed throughout the accelerator complex and is integrated into a significant number of control system components.

¹ Published as :

D. Beechy and R. Ducar, "Time And Data Distribution Systems At The Fermilab Accelerator", Nuclear Instruments and Methods in Physics Research A247 (1986)

*Operated by Universities Research Association, Inc. under contract with the U. S. Department of Energy.

1 INTRODUCTION AND HISTORY

The operation of the accelerator facility at Fermilab has been likened to the functioning of a vast multichannel predetermined (pre-det) timer. Hundreds of electronic devices must function in a time dependent fashion for the various accelerators to operate separately and together smoothly. As was the case for most previous accelerator facilities, specialized clock systems were developed at Fermilab to support the Linac, Booster, and Main Ring to orchestrate the operation of these machines. As the Main Ring became operational in 1972, separate clocks existed for the different accelerators - each utilizing different base band frequencies and encoding techniques. The Main Ring clock was extended to the beam lines to facilitate beam switching and coordinated data acquisition. All of these clocks incorporated coded markers that signified the reset of an acceleration cycle or some other major event within the cycle. A variety of techniques were used to encode these markers - most notably gaps, phase reversals, or both.

The advent of planning and construction of the Tevatron presented an opportunity to review the existing clock facilities. A total of five different clock systems were implemented at the time - generally not compatible but magically connected together with a myriad of cables to operate in a coordinated fashion. This was clearly not a base on which to provide the stringent timing requirements that the Tevatron demanded. Clocks do not disappear overnight. The designers followed the only reasonable course and began the specification of a sixth clock system - the Tevatron Clock. From the onset, however, the Tevatron Clock (TCLK) was hoped to eventually replace all previous clocks. For this reason, the number of different markers that could be encoded was set arbitrarily large (256) to accommodate all existing clock markers which numbered about twenty at the time.

As the design for the Tevatron proceeded, a significant operational problem surfaced due to the necessity of ramped Tevatron correction elements - some 216 in total. Instances of ramped elements for the extant facility were comparatively few. They were generally controlled from waveform generators driven by one of the existing time clocks. They were carefully programmed in time and amplitude to be in concert with the accelerator time and magnet current program. Changes in machine cycle times or energy necessitated laborious changes to these waveforms. The prospect of having to tune-up some two hundred additional elements has not met with much favor. At this time, a separate communications path was being specified to facilitate communications throughout the distributed quench protection monitor (QPM) system. Information as to the instantaneous value of Tevatron dipole current was included in these communications - exactly the data needed by a new style of waveform generator that could output a waveform as a function of dipole current rather than of time. Generation of the necessary waveforms for the Tevatron correction elements could then become a simple task with only a limited number of scale factors to manipulate. First efforts at implementing this system relied on each of the distributed QPM systems to provide necessary dipole current data to the element controllers. This approach was abandoned for a variety of technical reasons in favor of a separate communications link that broadcasts machine data (MDAT) throughout the accelerator complex.

More recently, with the anticipation of colliding beams within the Tevatron, the need for yet another clocking system became apparent. This new clock could be synchronous with circulating beam. Existing facilities supplied beam synchronous triggers to injection, extraction, and beam monitoring operations. These typically used dedicated cables, generally sourced from the Main Ring RF building, to a limited number of locations. All discriminated on beam, which often presented stability problems - especially with low intensities. The desire to upgrade the existing system and to facilitate exacting beam placement

necessitated for colliding scenarios led to the implementation of beam synchronous clocks for both the Main Ring (MRBS) and the Tevatron (TVBS).

2 TEVATRON CLOCK SYSTEM

The Tevatron clock (TCLK) at Fermilab is used to transmit important accelerator timing information to all major systems throughout the accelerator complex. Up to 256 unique events or timing markers may be encoded onto TCLK with typical resolution of 100 nanoseconds. 123 events have been implemented to date. The devices which listen and respond to events on TCLK now number in the thousands.

2.1 Signal Description

TCLK is a 10 MHz serial signal which uses an encoding scheme called bi-phase or modified Manchester coding. The coding is characterized by a transition at each 100 nanosecond bit cell boundary, with an additional transition at mid-cell if the bit is true and no transition at mid-cell if the bit is false. The direction of these transitions (high to low or low to high) is not specified and depends on the bit patterns transmitted and the word lengths. For the Tevatron clock, the word length of an event is always 10 bits (1 start bit, 8 data bits, and 1 parity bit).

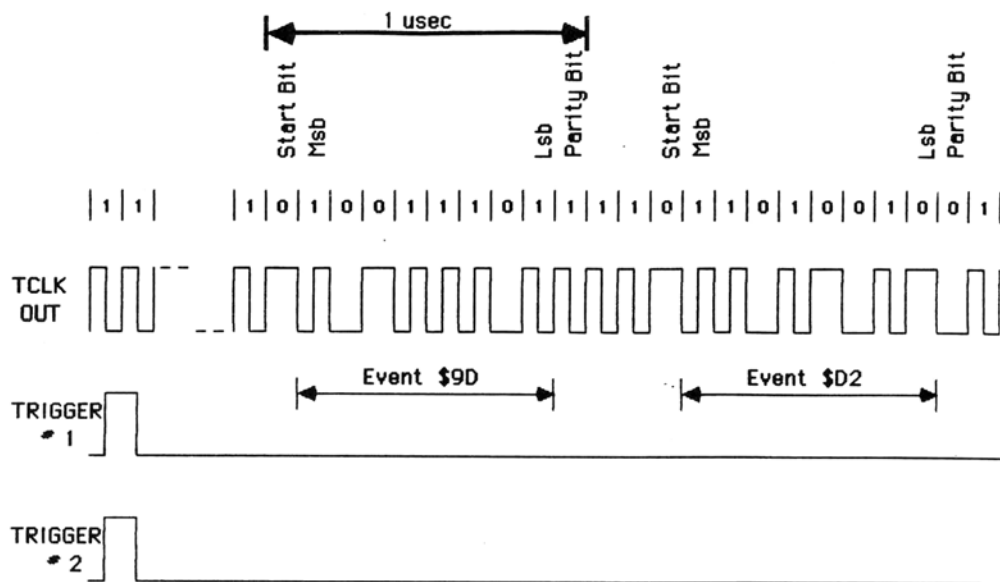

Figure 1

Tevatron Clock signal showing the transmission of clock events \$9D and \$D2.

Fig. 1 shows an example of two clock events, \$9D and \$D2, transmitted one after the other on TCLK. All TCLK transmissions begin with a leading start bit of 0. This start bit is used to inform all listeners that a clock event is forthcoming. Immediately following the start bit are the eight data bits which comprise the clock code, followed in turn by a single parity bit. Between clock codes, the clock transmitter transmits a continuous series of 1's. The transmitter is specified to always transmit at least two 1's after each clock event. This is the case depicted in fig. 1 where the triggers for the two events arrive simultaneously.

For those times when clock event activity is low, the clock signal appears as a 10 MHz square wave with occasional bursts of bi-phase patterns whenever clock events are transmitted. During those times when clock activity is high, the clock signal has no repeatable pattern. The TCLK signal is self-clocking, that is, it is possible to extract both the 10 MHz "carrier" and the encoded information from the composite signal without the need of additional clock signals.

2.2 Transmitting Hardware

The TCLK transmitter is made up of a parallel to serial to bi-phase converter coupled to up to 16 encoder modules called Event Request Modules (ERM) [1]. Refer to fig. 2. Each of the encoder modules contains 16 channels for a total capability of 256 channels, 1 for each of the 256 possible events on TCLK. Both the TCLK transmitter and the encoder modules are CAMAC based. Each of the channels of the ERM can be triggered externally or from the CAMAC dataway. Each time a channel is triggered an event is transmitted on TCLK.

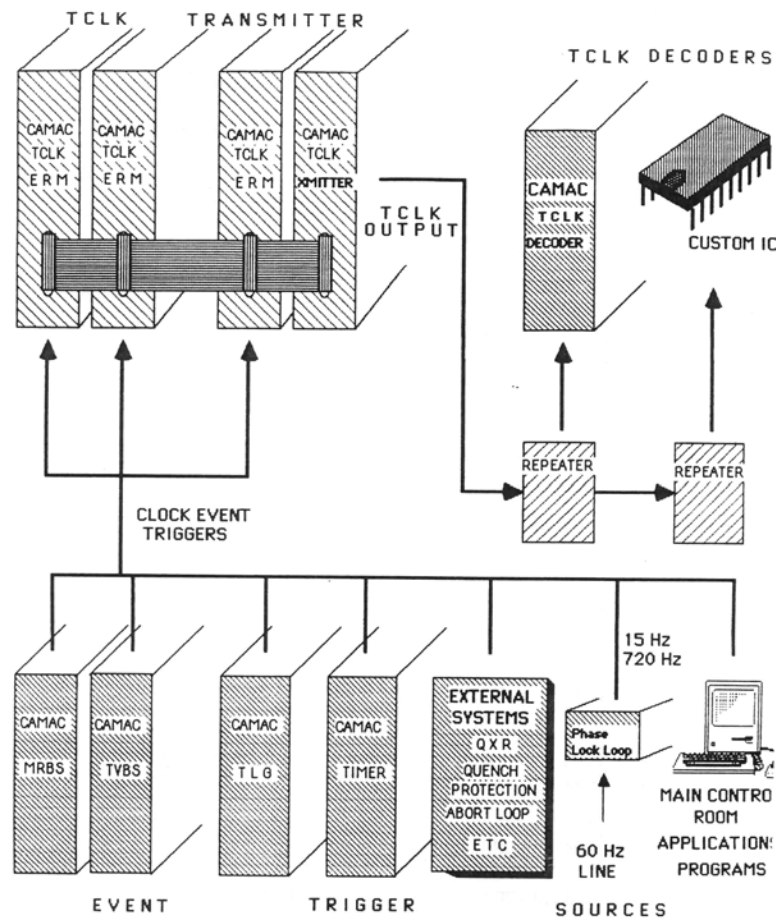

Figure 2

Tevatron Clock System

The 16 channels on each ERM are prioritized to allow for an orderly generation of clock events in the case of simultaneous triggers to two or more channels. Fig. 1 shows this situation. In addition, each of the Event Request Modules is part of a daisy chain priority scheme which establishes the relative priorities of event transmission. This allows event triggers to arrive at the encoder modules without

regard to possible timing conflicts with other triggers; however, low priority events may be delayed for several microseconds while transmission of higher priority events takes place.

The Event Request Modules are connected together via a front panel ribbon cable. This cable terminates at the transmitter which converts the parallel data to Modified Manchester code for transmission to distant points.

2.3 Clock Events

Since TCLK first became operational, a significant effort has been made to avoid the indiscriminate assignment of clock events to meet every request. It was "recognized early on that many systems throughout the accelerator complex needed to be linked to TCLK but that it would be unwieldy to supply all timing information directly via TCLK events. However, it was also recognized that a duplication of effort and equipment could be avoided if timing information for major distributed systems was carried on TCLK. The result has been that clock events now fall into two major categories with numerous subdivisions within each group. Refer to Table 1.

<u>MACHINE EVENTS</u>		
Machine Function	Machine	Number of Events
Reset (start of cycle)	Linac/Booster	9
	Main Ring	7
	Switchyard	2
	Tevatron	4
	Accumulator/Debuncher	5
Start/End Flattop	Main Ring	2
	Tevatron	2
Injection/Extraction/ Transfer	Linac/Booster	1
	Main Ring	3
	Tevatron	2
	Accumulator	1
Store/Colliding Physics	Tevatron	2
<u>SYSTEM EVENTS</u>		
Function	System	Number of Events
Periodic Timing Markers (720 Hz, 15 Hz)	Clock System	2
Data Acquisition	A/D System	5
Power Supply Ramping	Main Ring PS	1
	Tevatron PS	2
	Switchyard PS	2
	Tevatron Correction Elements	7
	Low Beta System	5
RF System Ramping	Tevatron RF	3
Beam Position Monitoring	Main Ring BPM	5
	Tevatron BPM	7
	Accumulator/Debuncher BPM	5
Control Room Facilities	Accelerator Computer System	all events

TABLE 1. Major Categories of Tevatron Clock Events

TABLE 1

General Categories of TCLK Events

The first category, machine events, contains clock events which inform listeners of important time dependent parameters for the various accelerators. It also has events which distinguish between the different types of machine cycles that are possible at any given time. For example, the Main Ring presently has seven different reset events to identify such cycles as "Reset for accelerated beam to P-bar target" or "Reset for backward injection from Tevatron" I etc. The Main Ring also has a number of events which distinguish the various transfers of beam into and out of the machine in the course of producing P-bars for colliding physics in the Tevatron. The second category, systems events, contains clock events which are used to control time dependent operations of the various systems throughout the complex.

Most of the systems listed above are both large and RF distributed, and also need to be synchronized to machine operation. The use of TCLK to do this task reduces the hardware (and software) overhead to a single system, thus eliminating unnecessary duplication of effort and increasing reliability. In all cases, an attempt has been made to avoid clock events which are specified for a single user. Rather, clock events tend to be general in nature and applicable to a wide variety of implementations. The end user is then responsible to listen and respond to these global events as the application requires.

The Controls Group at Fermilab provides several facilities for decoding TCLK and responding to selected events. These facilities are discussed in section 2.5. Table 1 shows in general terms the division of clock events on TCLK. A partial listing of presently assigned clock events is in Appendix 1.

2.4 Clock Event Triggers

The triggers which initiate the events discussed in the previous section come from a variety of sources associated with the functions of the various accelerators. Table 2 groups these different triggers into five main categories. Refer also to fig. 2 which shows these trigger sources linked to the TCLK encoding modules.

FUNCTION	TRIGGER SOURCE
Periodic Timing Markers	Phase Locked Loop
Resets (Start of cycle)	Time Line Generator
Variable Events	Timing Modules
System Generated Events	Quench Protection, MRBS, TVBS, QXR, Abort Loop, etc.
Manual Events	Operator/Applications programs [2,3]

TABLE 2

Clock Event Triggers

2.4.1 Periodic Timing Markers – Presently, two timing markers are broadcast on TCLK: a 15 Hz event and an event which occurs at 720 Hz. See section 3.0 for an example of the 720 Hz event used with the MDAT system. These two events are derived from the 60 Hz power line signal.

2.4.2 Machine Cycle Resets - Resets for the various machine cycles which are used in the accelerator are triggered by a Time Line Generator (TLG) [4]. The TLG consists of two CAMAC based modules that provide a total of 32 outputs each of which can be used to trigger a clock event. The TLG operates by sequentially stepping through a table of 8192 words, each word being 32 bits in length and each bit corresponding to one of the TLG outputs. Each of these words also corresponds to a single 67 millisecond time period. During that period, those outputs from the TLG are active for which the

corresponding bits are set in memory. The sequencing rate of 15 Hz can provide several hours of programmed cycle timing.

2.4.3 Variable Events - Many of the machine dependent and systems-dependent clock events shown in Table 1 are generated with both high precision and high resolution from programmable timing modules which are part of the TCLK system. These modules are either programmed manually from the Main Control Room using a TCLK applications program or automatically by the same software which calculates parameters for the TLG. These timing modules are triggered to start counting by other clock events - most often by those events which signal the start of the different machine cycles. This technique of referencing clock events to a relatively few major reset events allows many time dependent events to change automatically whenever accelerator parameters change.

2.4.4 System Generated Events - Many systems throughout Fermilab supply event triggers to the TCLK transmitter. For example, most of the events which signal the injection or extraction or transfer of beam between machines are derived from the two beam sync signals, MRBS and TVBS (see section 4). Events on MRBS and TVBS are decoded and subsequently used to trigger corresponding events on TCLK. Clock events which indicate that various faults have occurred are triggered from the system which detects the fault. For example, when the Quench Protection Monitor detects a quench in the Tevatron, a signal is sent to TCLK to trigger an event signifying that a quench has occurred. This event is decoded by various power supply controllers which quickly ramp the supplies down to zero current to limit the effects of the quench. Other systems like the Abort Loop similarly inform TCLK whenever a fault is detected. QXR, the Quadrupole Extraction Regulator, is used to generate the fast and slow beam spills from the Tevatron. Triggers from QXR generate clock events which synchronize operations in the Switchyard beam lines.

2.4.5 Manual Events - Some clock events are not generated periodically and are only initiated by operators in the Main Control Room. These events require no special trigger hardware and are initiated simply by sending CAMAC commands directly to the appropriate channel of the TCLK transmitter.

2.5 Receiving TCLK

In view of the fact that large numbers of devices require TCLK information, the Controls group has made an effort to provide easy access to the signal and to decode the various clock events from the signal. Generation of TCLK takes place centrally and, after modulating a 50 MHz RF carrier, the combined signal is distributed on coax cable to nearly all parts of the site via an extensive repeater network. These include the beam lines in the experimental areas, Switchyard, all Main Ring and Tevatron service buildings, the Booster galleries, the new Accumulator/Debuncher service buildings, and various computer installations and engineering labs. The signal is even indirectly broadcast off site for the purpose of taking radiation measurements during various segments of the machine cycle.

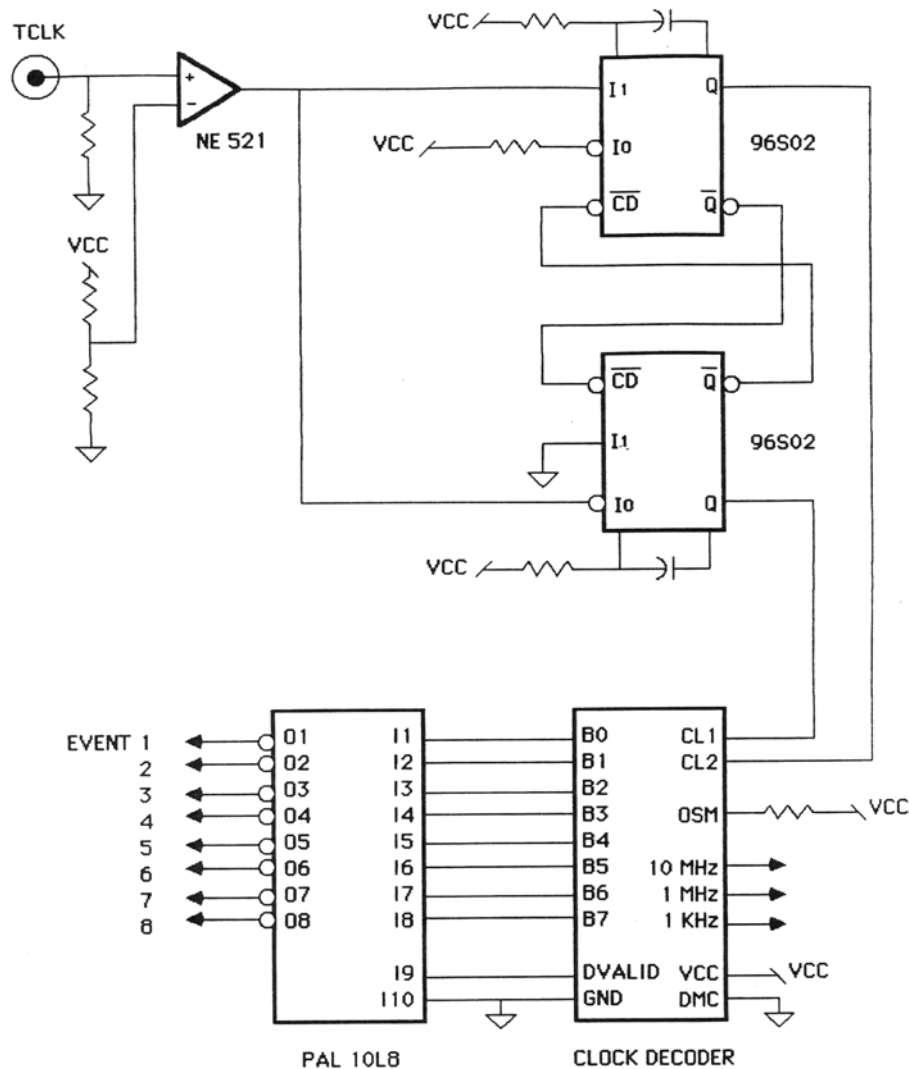

Figure 3

TCLK Decoding Circuitry

Decoding of the TCLK signal, after it is demodulated from the RF carrier, is provided at the module level by a variety of different CAMAC modules and at the chip level by a custom integrated circuit designed at Fermilab [5,6,7]. The CAMAC modules allow for simple decoding of selected events or in more demanding applications a programmable delay is provided after the receipt of a selected clock event(s). The outputs of these modules are TTL compatible pulses which may be used to trigger various types of external equipment. Other CAMAC modules provide for the gating of clock events, the setting and resetting of flip flops by clock events, or a combination of gating and delay from selected events. The custom Fermilab Clock Decoder integrated circuit facilitates decoding the clock signal for those systems where it is necessary to include the decoder internally on board rather than externally. A complete TCLK receiver is formed by the decoder integrated circuit, a 24 pin device, and three other ICs. Fig. 3 is an example of a typical receiver circuit. The NE521 comparator produces a high quality TTL signal to the cross coupled one-shots. The custom IC separates the clock and data and outputs every clock event in parallel format, with an appropriate enable signal, to either a PAL or EPROM device. The

final output is determined by the PAL or EPROM as programmed by the user. Over 1500 of these custom ICs have been used to date.

3 MACHINE DATA DISTRIBUTION SYSTEM

Machine data distribution is accomplished by means of a separate communications link that is distributed throughout the accelerator complex. The data broadcast on this link is in the form of separate serially encoded data frames, each including an 8 bit type code and an associated 16 bit word of data. At present there are five different frames, each transmitted at a 720 Hz rate. Data transmitted are the Tevatron dipole current, the time derivative of the Tevatron dipole current, and the measured Main Ring dipole current. Both the programmed and measured values of the Tevatron parameters are broadcast.

MDAT FRAME FORMAT

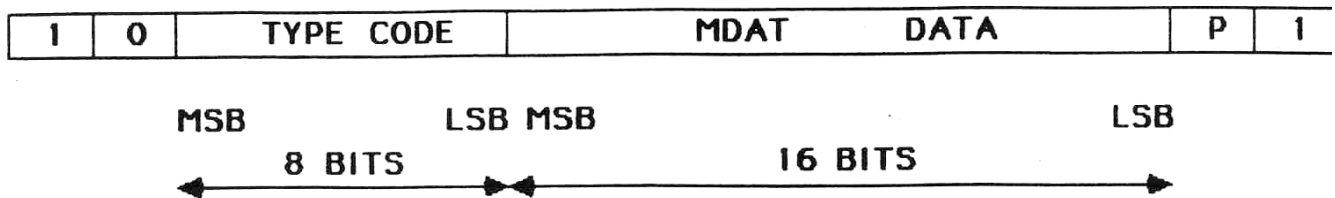

Figure 4

MDAT Protocol

The MDAT serial frame is 28 bits in length, self clocking, and operates at a 10 MBit per second rate. Parity is such that the frame is always 2.75 microseconds in length. Commercially available components are implemented in the receiver circuit for MDAT, rather than a custom IC as is the case for time and beam sync clocks. Ramped element controllers receive both MDAT and TCLK and generate waveforms that may be both a function of time and of a MDAT parameter. These generators have interpolation capability and typically update at a 1 KHz rate. In addition to ramped elements, the Tevatron RF system is driven by waveforms that are generated from MDAT parameters.

Each MDAT frame is sourced by a custom parallel/serial converter packaged in a single CAMAC module. The Tevatron power supply computer (TECAR) provides all the Tevatron data and a precision transducer provides the Main Ring parameter. All individual frames are ultimately or'd together at the Main Control Room of the accelerator. The composite signals are then broadcast over existing 10 MBit link systems to the Tevatron and Switchyard control systems.

Additional frames may be supported in the future. These will likely include the derivative of Main Ring dipole current and beam intensities for both the Main Ring and Tevatron.

4 MRBS & TVBS

There have been longstanding requirements to have available various beam synchronization signals to properly control the injection, extraction, and beam monitoring operations of the accelerator complex. A

variety of schemes have been implemented in the past, generally unique to a particular requirement. The demands of synchronizing Debuncher and Accumulator operations to the Main Ring have recently presented new requirements that forced a more coherent systems approach.

In 1984 a new type of clock system was proposed to satisfy the requirements at hand. Initially it was thought to be a 10 MHz clock that would be phase locked to the Main Ring RF frequency. Already developed Tevatron Clock hardware could be used directly with this new system as well as already developed link repeater hardware. This new clock would carry special events or time markers synchronous with beam and events that would initiate injection, extraction, or targeting operations. It would also provide the capability of diagnostic timing at every service building of the accelerator.

The success of this first approach hinged on being able to create a stable 10 MHz to 53 MHz phase lock. Given the dynamic range of the RF and the response of high frequency phase lock loops, the 10 MHz base frequency was abandoned. Chosen instead was a sub-harmonic of the Main Ring RF frequency. The Main Ring RF frequency divided by seven is approximately 7.5 MHz, a rate that is reasonably close to the existing clock frequency. But it is more significant that the Main Ring harmonic number of 1113 is evenly divisible by seven. The result is a constant 159 clock ticks per turn of beam. This was the gateway to a straightforward implementation of beam synchronous clocks that utilized existing TCLK technology that had already proved itself. Simple timing modifications were made to existing TCLK and repeater hardware to handle the slower clock frequency. Countdown NIM modules were built for the Main Ring, Proton Tevatron, and P-Bar Tevatron RF systems. These provided the base clock as well as revolution synchronous pulses to modified TCLK generator hardware. The revolution synchronous pulses are encoded onto the beam sync clocks every machine turn.

The presence of revolution events, which are always present without regard to the status of either the high level RF system or the presence of beam within the accelerator, has been of immense utility. Minor modifications to Booster extraction timing hardware has allowed the synchronous loading of beam into the Main Ring with respect to the Main Ring beam sync clock (MRBS). Extraction of beam from the Main Ring is now routinely accomplished using the revolution marker as reference. A separate beam sync clock for Proton Tevatron RF (TVBS) has been implemented in similar fashion. Newly installed transfer cogging hardware effects a definite phase relationship between MRBS and TVBS revolution markers before the transfer of beam from Main Ring to Tevatron.

Capability exists for additional markers on these clocks which initiate beam transfers between machines. Transfer timing has been significantly simplified as a result. Additionally, beam position system flash triggers are easily synchronized to circulating beam. Examination of beam orbits immediately before and after transfers are now possible.

The measured jitter of the new beam sync clocks relative to actual beam is less than ± 2 nanoseconds at any measurement point in the accelerator.

5 CONCLUSION

The implementation of the aforementioned time and data distribution systems has been extremely successful. They are used throughout the facility and operate with a minimum of downtime. There is a general trend to convert pre-Tevatron controls hardware to these new facilities to gain advantage of increased flexibility of operation. TCLK has been especially instrumental in allowing parasitic machine studies to be conducted in concert with the fixed-target program.

References:

1. D. G. Beechy, Fermilab Controls Hardware Release 29.0 (1983) unpublished.
2. T. Watts, Fermilab Controls Software Update 211, unpublished.
3. R. W. Goodwin & R. P. Johnson, "Coordinated Control of the Energy and Time Dependent Parameters of the Tevatron", 12th International Conference on High Energy Accelerators, Fermilab, 1983.
4. W. R. Knopf, Fermilab internal memo (1985) unpublished.
5. R. J. Ducar, Fermilab Controls Hardware Release 36.1 (1984) unpublished.
6. R. J. Ducar, Fermilab Controls Hardware Release 43.0 (1985) unpublished.
7. D. G. Beechy, Fermilab Controls Hardware Release 20.0 (1983) unpublished.

Appendix 1

Partial list of TCLK Events and Definitions

00 Clock: Super Cycle & Master Clock Reset

07 Clock: 720 Hz (line locked)

0F Clock: 15 Hz (line locked)

12 BSTR: Reset for beam pre-pulse cycle

13 BSTR: Reset for accelerated beam to Main Ring for Tevatron fixed-target extraction

14 BSTR: Reset for accelerated beam to Main Ring for P-Bar production

15 BSTR: Reset for accelerated beam to Main Ring for Tevatron colliding physics -Bunch A

16 BSTR: Reset for accelerated beam to Main Ring for transport to the Debuncher or Accumulator

17 6STR: Reset for accelerated beam to the Debuncher

20 MR: Reset for backward injection from Tevatron cycle

21 MR: Reset for accelerated beam to Tevatron for fixed-target extract

27 MR: Beam has been aborted

29 MR: Reset for accelerated beam to P-Bar target

2A MR: Reset for accelerated P-Bar beam to Tevatron for colliding physics

2B MR: Reset for accelerated beam to Tevatron for colliding Physics

2D MR: Reset for coasting beam cycle

41 Tev: Reset for accelerated beam for fixed-target extract

48 Tev: Abort system reset

49 Tev: Reset for accelerated beam for collider mode

4D Tev: Reset for coasting beam cycle

4E Tev: Tevatron quench

69 Tev: Low beta squeeze F0 --Start

77 Tev: BPM -flash trigger

7C MR: BPM -flash trigger

81 DBUN: Production cycle reset (MRBS \$79)

84 DBUN: BPM -Measure closed orbit

90 ACUM: Stack cycle reset

9A ACUM: Unstack cycle reset -Bunch X (High intensity)

Appendix 2

Currently Assigned MRBS Events and Definitions

AA Revolution Frequency

BB Revolution Frequency + 1/3 Turn

CC Revolution Frequency +2/3 Turn

77 Booster Extraction Timing Reset

78 Initiate Main Ring to Tevatron Transfer (Fixed Target Physics)

79 Initiate Main Ring to P-Bar Target Transfer

7A Initiate Accumulator to Main Ring Transfer (P-Bars for Colliding Physics)

7B Initiate Main Ring to Tevatron Transfer (P-Bars for Colliding Physics)

7C Initiate Main Ring to Tevatron Transfer (Protons for Colliding Physics)

7D Initiate Booster to Debuncher Transfer

7E Initiate Main Ring to Accumulator Transfer (Test Beam Transfer Line)

Appendix 3

Currently Assigned TVBS Events and Definitions

AA Revolution Frequency

BB Revolution Frequency + 1/3 Turn

CC Revolution Frequency +2/3 Turn

D7 Initiate Tevatron to Beam Line Transfer

D8 Initiate Tevatron to Main Ring Transfer (Protons to Check MR to Tev P-Bar Injection Line)