

Signal to Noise and Dynamic Range Issues in System Design

Ralph J. Pasquinelli
Fermilab, Batavia, Illinois 60510*

Abstract

Study of signal to noise and dynamic range of systems is a very important part of engineering. The topic of signal to noise has been covered extensively in the literature, but not necessarily from a practical standpoint. Discussion of dynamic range issues is virtually missing from most fundamental texts. This paper will attempt to present practical ways of looking at system design. For completeness, the fundamental equations will be included, but the emphasis will be on real system implementation. The paper will draw extensively from actual system designs at Fermilab.

Sources of Noise

The random motion of electrons in materials due to temperature is a source of noise known as thermal noise. Electrons moving as a current through a solid state device or vacuum tube can generate shot or Schottky noise. In the case of an accelerator, shot noise can come from any source of accelerated charge, i.e. electrons, positrons, protons, and antiprotons. Sometimes the beam itself becomes the largest source of noise in an accelerator system. This noise can take the form of poor common mode rejection in a pickup device. All of these sources of noise tend to get in the way of analyzing the desired signal or waste precious kicker power in closed loop systems.

Figure 1 is a listing of the common equations used to calculate noise performance in systems. There is often confusion between the terms Noise Factor and Noise Figure. In this paper, Noise factor is the linear relation between noise on the output referred to the input and Noise Figure is the logarithmic relation expressed in dB.

Also included is the term of Effective Noise Temperature. Noise Figure and Noise Factor are commonly related to a room temperature of 290 degrees Kelvin. A 3 dB Noise Figure or a Noise Factor of 2

*Operated by Universities Research Association under contract with the U.S. Department of Energy. AIP Conference Proceedings 319, Beam Instrumentation Workshop; Santa Fe, New Mexico, 1993

indicates double the input noise on the output, which for most terrestrial applications is the equivalent Effective Noise Temperature of 580 degrees Kelvin. For space or cryogenic applications, the ambient temperature is not 290 degrees Kelvin. The use of Effective Noise Temperature allows convenient arithmetic to calculate noise performance. For example if a pickup has an 80 degrees Kelvin termination temperature and the preamp has an Effective Noise Temperature of 20 degrees Kelvin, the front-end noise performance is 100 degrees Kelvin.

$$\text{Noise Factor} = \frac{\text{Signal In}}{\text{Noise In}} \div \frac{\text{Signal Out}}{\text{Noise Out}} = \frac{\text{Signal In}}{\text{Signal Out}} \times \frac{\text{Noise Out}}{\text{Noise In}}$$

$$\text{Noise Power} = K \times \text{Temperature} \times \text{Bandwidth}$$

$$\text{Noise Factor} = \frac{\text{Noise Power Out}}{K \times \text{Temperature} \times \text{Bandwidth}}$$

$$\text{Noise Figure (dB)} = 10 \times \text{Log}(\text{Noise Factor})$$

$$\text{Noise Figure (dB)} = 10 \times \text{Log}\left(\frac{T_2 - T_0}{T_0}\right) - 10 \times \log\left(\frac{N_2}{N_1} - 1\right)$$

$$\frac{N_2}{N_1} = Y_Factor$$

$$\text{Noise Figure (dB)} = 10 \times \text{Log}\left(\frac{T_2 - T_1 \times Y}{290 \times (Y - 1)} + 1\right)$$

$$\text{System Noise Factor} = NF_1 + \frac{NF_2 - 1}{\text{Gain}_1} + \frac{NF_3 - 1}{\text{Gain}_1 \times \text{Gain}_2} + \dots$$

$$\text{Effective Noise Temperature} = 290 \times [NF - 1]$$

Figure 1. Basic noise equations. Note that Noise Factor (NF) is not in dB. K in all equations is Boltzman's constant = 1.38×10^{-23} watt sec/degrees Kelvin. Temperature is in degrees Kelvin.

Noise Floor

The term noise floor is used often to describe the amount of noise power in a system. The noise floor of most systems depends on the thermal noise at the input. The noise energy is measured in joules and is $\text{Noise Energy} = KT$ (joules or watt seconds)

where K is Boltzman's constant, 1.38×10^{-23} joules/degrees K. For convenience of scaling, it is always desirable to note noise power in a 1 Hz bandwidth. If T is room temperature of 290° K, then

$$KT = 4 \times 10^{-21} \text{ joules} = 4 \times 10^{-18} \text{ milliwatt sec}$$

convert to dBm in one Hz bandwidth,

$$KTB = -174 \text{ dBm/Hz (room temp of } 290^\circ \text{ K)}$$

For an ideal spectrum analyzer at room temperature that has 1 MHz of resolution bandwidth, the noise floor would be 60-dB higher or -114 dBm. Inspection of figure 2 shows that an expensive spectrum analyzer has a noise floor of -91 dBm which is much worse than ideal. This of course is due to input losses, front-end mixers. etc.

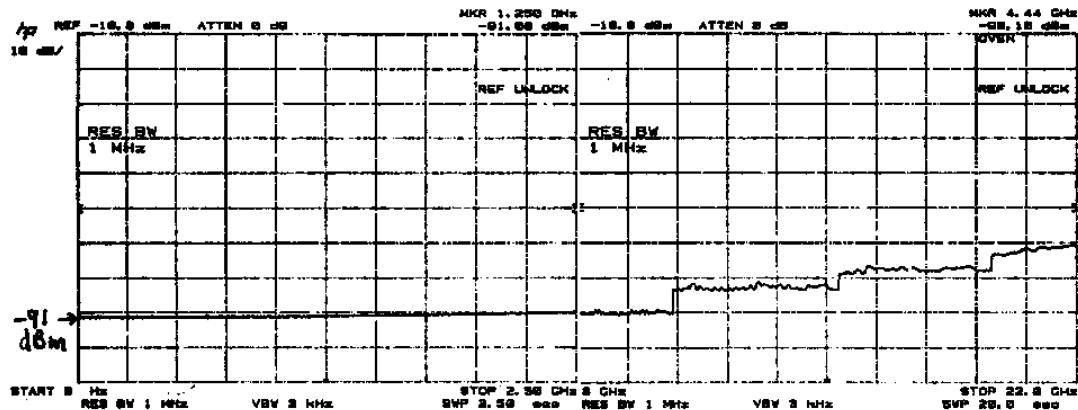

Figure 2. Noise floor performance of HP 8566 spectrum analyzer. Span is from DC to 22 GHz, noise floor is -91 dBm at best.

Thermal Noise Example

The stochastic cooling systems¹ of the Fermilab Antiproton source are an excellent example to study Signal to Noise issues in system design. Figure 3 shows a simplified diagram of a closed loop system. In the case of stochastic cooling, the signal is the shot noise of the antiproton beam. The noise is the thermal noise floor of the system. (The beam also generates unwanted shot noise as well, but more about that later.) Because the source of antiprotons on our planet is non-existent, we have to manufacture them by targeting protons on a copper target and collecting the 10 part per million yield.

When this small beam current (nano-amps) goes through the pick up array, a small signal is developed on the order of 10 picowatts.

Let us take an example of a final system. Most of the cost in a feedback system is typically in the final high power amplifier. For this example, use the cost of \$100 per watt. Careful analysis of the signal to noise ratio in a system can save money and provide the best performance. After all the gain calculations have been done, a system specification can be generated. Most machines also have a very limited amount of physical space to locate a kicker. All kickers have a maximum power capacity, so it is critical to make the best use of the installed power. As can be readily seen at this point, there are real restraints on building an actual system.

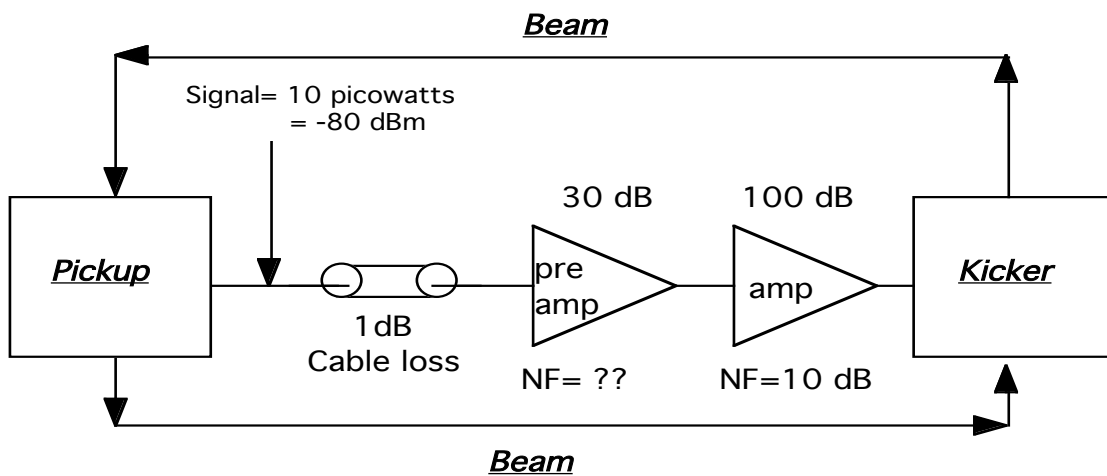

Figure 3. Typical stochastic cooling feedback system block diagram.

So here are the specs:

Amount of kicker signal power.....100 watts, +50dBm
Amount of pickup signal power.....10 picowatts, -80 dBm
System Bandwidth..... 1 GHz

Upon first inspection, a casual observer might just say, "That's easy, we just need 130 dB of gain and the project is over!" In reality, it is very important to carefully analyze the system and calculate the thermal noise power in the pickup with the given bandwidth. This is simply KTB where K is Boltzman's constant, T is the temperature in degrees Kelvin, and B is the system bandwidth in Hertz. If we assume that our pickup will be at tunnel temperature of 27 degrees C or 300 degrees K, we can now find the thermal noise power. 4.14×10^{-12} watts or -83.8 dBm. We will analyze three cases of front-end hardware.

Case I will have a preamp that has a 3-dB noise figure. The cable at the input to the amplifier has 1 dB insertion loss and is the first stage in the gain chain. Using the equations presented earlier one can figure the noise factor of this system to be 2.52, noise figure of 4.01 dB, or effective noise temperature of 441 degrees Kelvin. Note here that the noise performance is dominated by the two first devices in the gain chain and that loss before the preamp directly degrades the noise performance. Multiplying the input by the 129-dB total gain will give a total of 79 watts of signal. Noise on the output referred to the input is the definition of noise factor, for 83 watts of thermal noise at the kicker and a signal to noise ratio (SNR) of -0.2 dB. Total power is 162 watts.

Case II involves going to the store and buying a more "state of the art" preamp that has a noise figure of 1 dB. The noise factor for this system is 1.58, noise figure of 2 dB, and noise temperature of 168 degrees Kelvin. At the kicker, we will see the same 79 watts of signal but now only 52 watts of noise for a SNR of 1.8 dB. Total power is 131 watts.

Case III will use the same 1 dB noise figure amplifier but put the pickup and preamp in a cryo environment of 80 degrees K. We also decide to get rid of the 1-dB insertion loss cable because the preamp is now part of the pickup. The noise power on the input has a new KTB value of -89.6 dBm; the signal power remains unchanged. The noise factor of this system is 1.26, noise figure of 1.0002dB, and effective noise temperature of 75 degrees Kelvin. In this system, the kicker will see 100 watts of signal and only 14 watts of noise for a SNR of 8.6 dB. Total power is 114 watts.

This performance comes at what cost. Remember that the system spec calls for 100 watts of signal, so for Case I & II an additional 26% of total power is necessary to go from 79 to 100 watts of desired signal. The cost comparison is based on front end and power costs. It is assumed that all the connections in between are the same in all cases.

Case I.	Preamp cost	\$500
	<u>Power cost</u>	<u>\$20,500</u>
	Subtotal	\$21,000

Case II	Preamp cost	\$1000
	<u>Power cost</u>	<u>\$16,500</u>
	Subtotal	\$17,500

Case III	Cryogenic cost	\$50,000
	Preamp cost	\$1000
	<u>Power cost</u>	<u>\$11,400</u>
	Subtotal	\$64,400

Note that in case III due to cryogenics, the cost is more than triple but cannot be ruled out. In the case of the stochastic cooling systems at Fermilab, the kicker power cost is between \$300 and \$500 per watt. For this reason, the cost of refrigeration saved dollars but more importantly provided the required performance.

Be aware also that the actual kicker may only have a power rating of 100 watts, or that there is limited space for adding extra kickers to handle the excess noise power, or there might be possible saturation of the kicker if ferrites are employed.

All amplifiers unfortunately reach saturation at some power level. In the case of the 100-watt amplifier, is 100 watts the linear output power, the one dB compression power or the saturated output power? As saturation is approached, the power amplifier also becomes a source of noise in the form of intermodulation distortion. For a wide band system, it is probable that odd order intermodulation products will be in the pass band as is shown in Figure 4. If the conditions of your system cannot tolerate the intermodulation noise it may be necessary to degrade your one hundred-watt amplifier to 50 watts or less making the dollars per watt increase accordingly.

Shot Noise Example

As an example of a noise source other than thermal, take for example an optical amplifier produced by BT&D. This device is an optical to optical amplifier; no electrical signal regeneration is required. The amplifier is similar to a semiconductor laser diode biased below threshold. The reflective coatings have been removed so that lasing does not occur. Amplification occurs (bi-directionally) when incoming photons create stimulated emission in the device junction. Figure 5 shows the shot noise performance of this device as a function of bias current. The larger the bias current the higher the gain, but at the expense of added shot noise. This device has been used to create a unity gain optical storage ring that functions as a recursive "brick wall" notch filter for bunched beam stochastic cooling in the Fermilab Tevatron.²

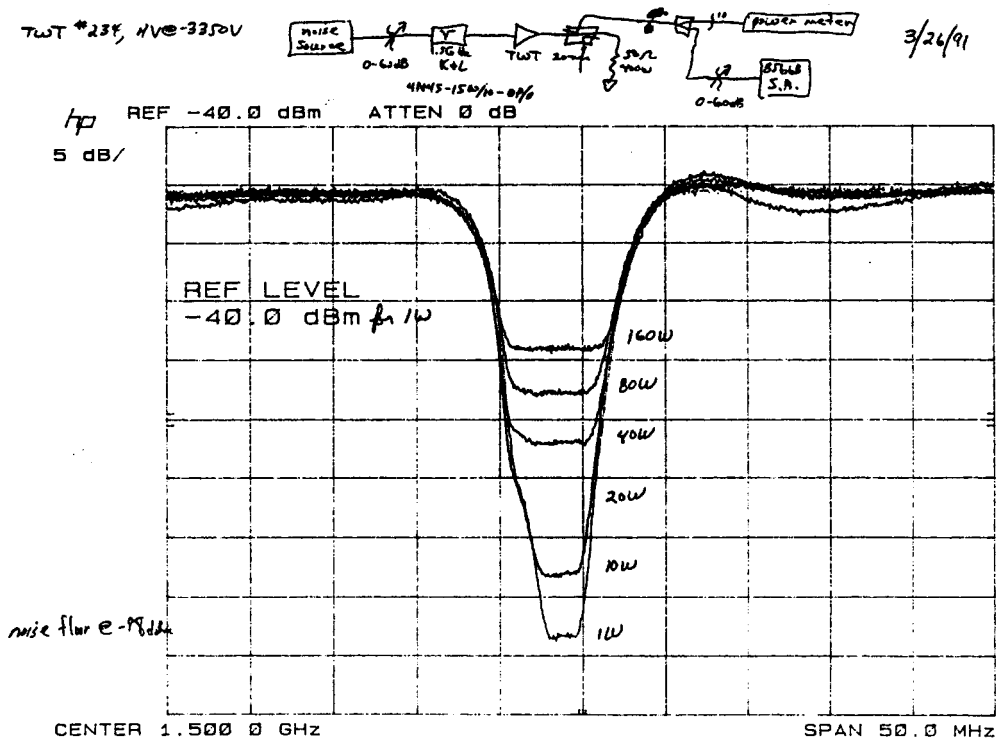

Figure 4. Odd order intermodulation distortion of a traveling wave tube amplifier. Tube is driven with a notch filtered white noise source.

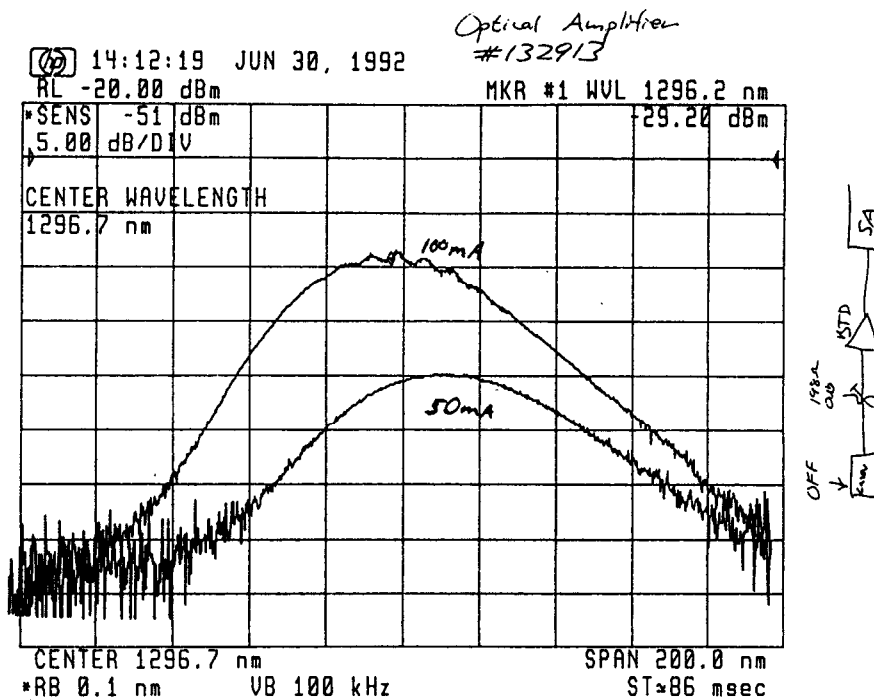

Figure 5. BT&D optical amplifier. Shot noise at the output is shown for two different bias points.

Beam Noise Example

In the accelerator environment, there are other sources of noise besides thermal and shot. The beam signal may itself be a huge source of noise. When attempting to analyze the transverse aspects of a beam signal, the longitudinal portion of the signal spectrum presents a "noise problem". The issue of dynamic range also comes up with this example. For a bunched beam circulating in an accelerator, the spectrum may very well look something like figure 6. The transverse information is in the betatron sidebands and is the useful signal. The large longitudinal line is unwanted noise that will also be amplified. Assuming flat gain in the pickup, a signal to noise ratio can be computed for this spectrum. Clearly, the unwanted longitudinal line dominates the power output. The longitudinal beam signal presents noisy watts that may or may not affect the beam in a feedback system or cause saturation of a preamplifier. Nonetheless, they are very expensive useless watts. How to get rid of them? There are two possible techniques used to reduce the longitudinal line, one is better common mode rejection in the pick up electrodes. This requires excellent mechanical tolerances and the best differencing circuit you can find or build. The second is to build some kind of filter that will only affect the longitudinal line leaving the gain and phase of the sidebands untouched.² Of course, complete elimination of the lines would require infinite common mode rejection, which is not a realistic expectation. Even with your best effort, there will always be some of the unwanted signal remaining. As shown with the thermal noise case, compromises are required to obtain the best possible performance.

Dynamic range

What is dynamic range? A careful search through the indexes of many engineering texts books comes up empty. Something so very important is never really taught at the basic level. In words, it is the ratio of the maximum available output power and the noise output power of a device at its rated gain.

$$\text{Dynamic range} = \text{Maximum Power Out/Noise Power Out}$$

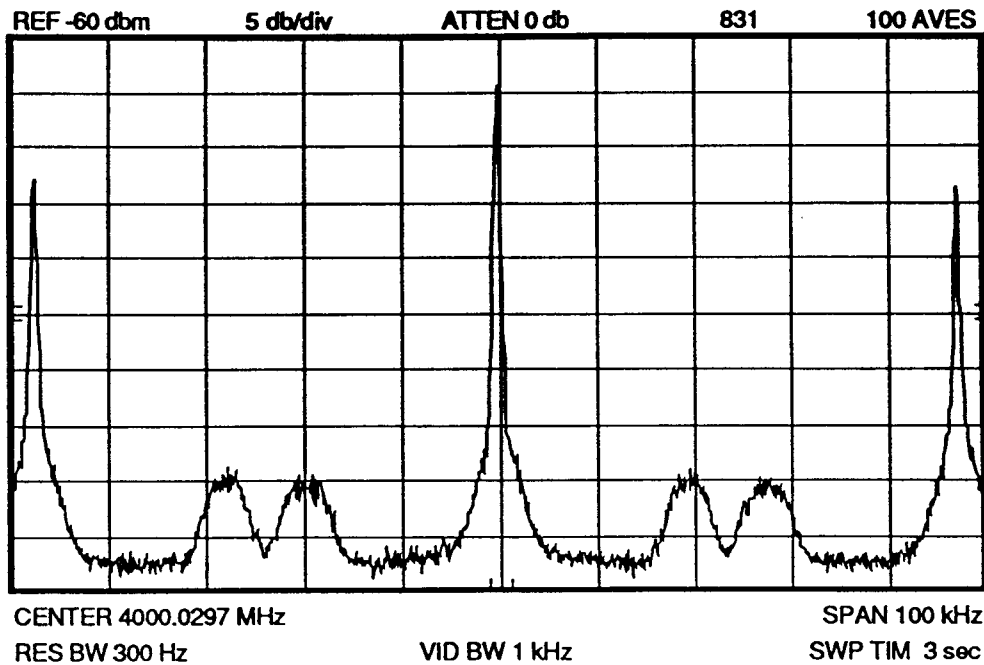

Figure 6. Spectrum of bunched beam cooling signal in Fermilab Tevatron. The large coherent signal in the middle is unwanted longitudinal beam signal that behaves as system noise.

All devices are specified with a maximum input or output power over a specified bandwidth. Take for example an amplifier that is capable of delivering one watt of power over a wide bandwidth. At any single frequency, the unit should provide one watt. If the application is wide band, then only a fraction of a watt can be delivered at any given in band frequency. This in turn changes the dynamic range of the amplifier. A narrow band application will have a higher dynamic range over a wide band system using the same device. Figure 7 graphically shows the effect.

A practical example of this effect can be seen in a very wide band optical transmitter such as the Ortel 5515B. This unit has 12 GHz of modulation bandwidth but a maximum drive power level of 10 milliwatts. As can be seen in Figure 8, the noise floor also increases as modulation bandwidth increases (KTB again). The dynamic range can be maximized with narrow band modulation, but will suffer as bandwidth increases.

Peak vs. Average Power

The tools available to investigate signals are network and spectrum analyzers for the frequency domain and oscilloscopes for the time domain. Each domain has its pluses and minuses. Peak amplitude will cause devices to saturate and is easily observed in the time domain. For example figure 9 is a sequence of three oscillographs of the same signal viewed in three different places in the gain chain of the bunched beam cooling system of the Tevatron³. There are two adjacent bunches in the accelerator, the main bunch and an

unwanted satellite. The unwanted satellite does give us a good indication of amplifier saturation. It is evident that saturation has started after the second amplifier. This same information in the frequency domain is not obvious as a spectrum analyzer displays the average power. Similarly, when the information is frequency related such as Schottky signals in figure 6, the frequency domain is preferred.

The signals used in the previous example were actually the same signal. Using both domains prove to be valuable tools in understanding the system.

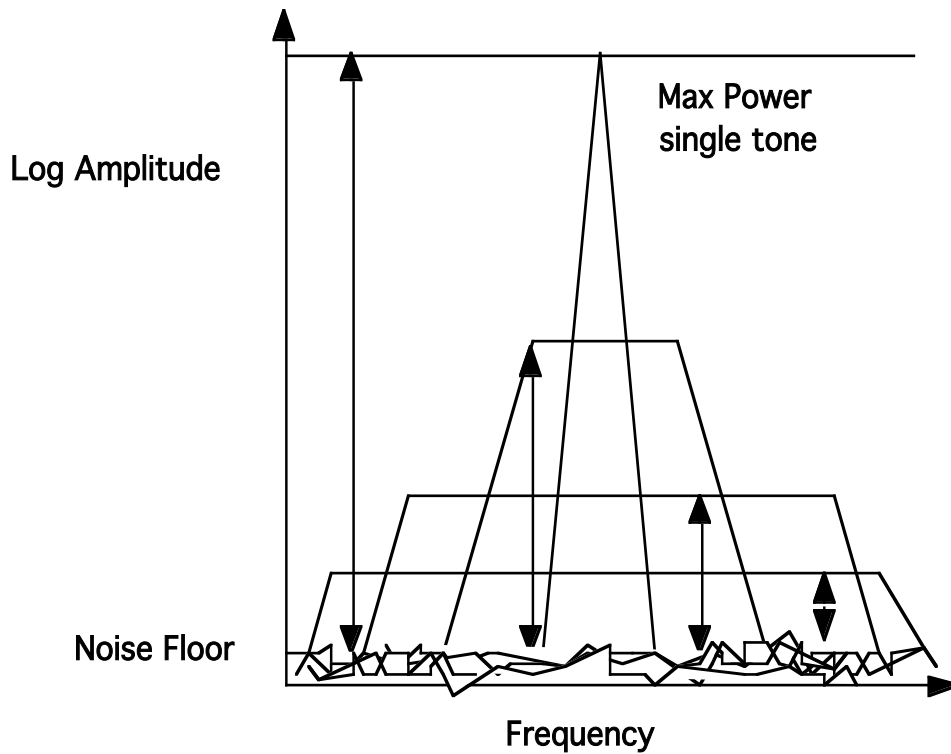

Figure 7. Narrow band operation has larger dynamic range than wide band for the same device due to maximum power limitations.

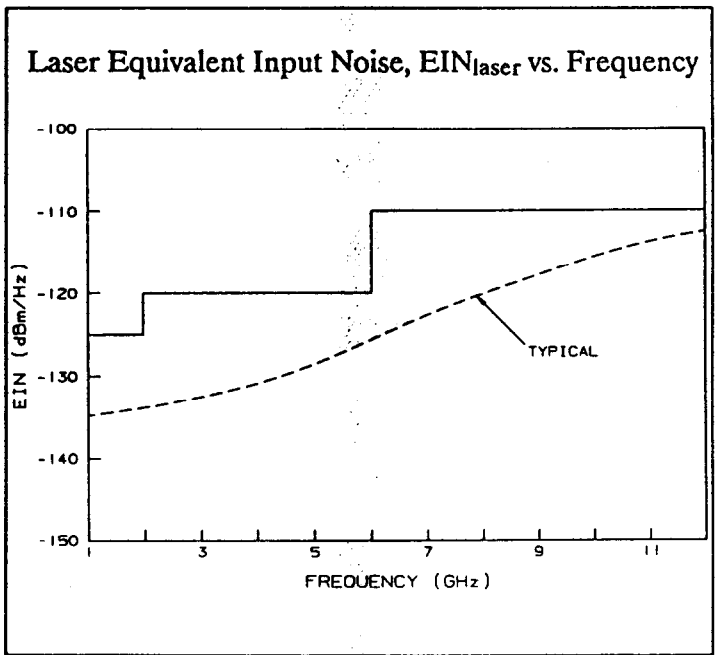

Figure 8. Noise performance of Ortel 5515B laser transmitter.

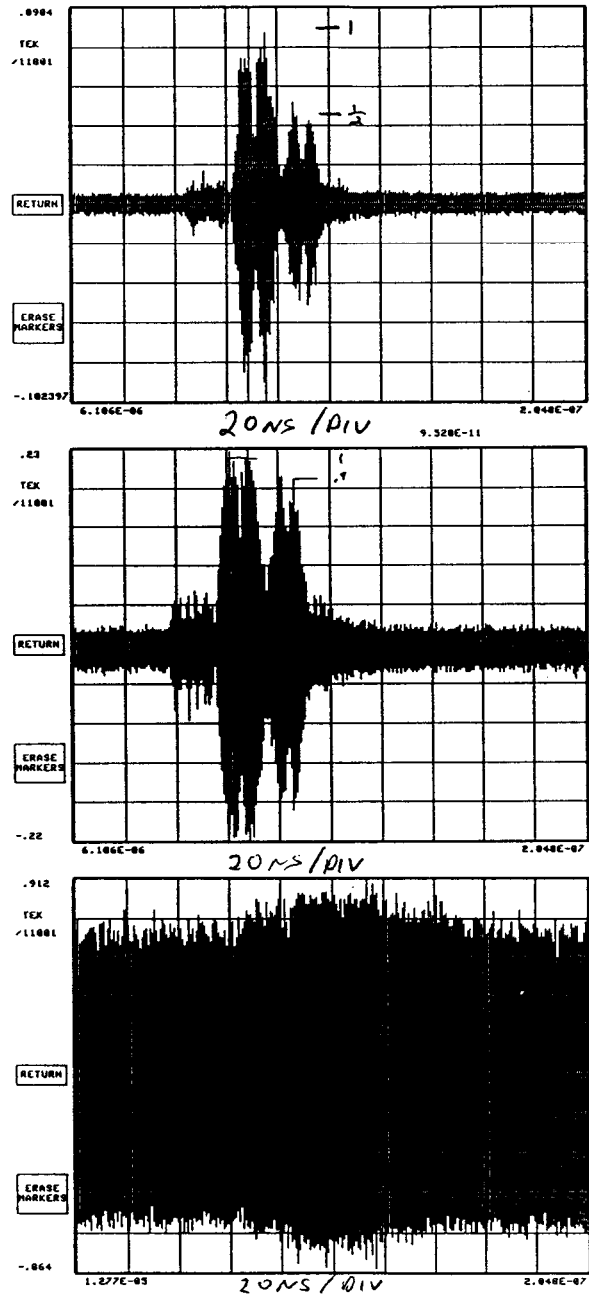

Figure 9. Sampling oscilloscope traces of bunched beam cooling system in the Tevatron. Top trace is signal after first preamp. Middle trace same signal after second amplifier. Bottom trace same signal after TWT amplifier.

Gating

In the case where the signal is not continuous (most accelerators have beam with a bunched structure) gating can be used to improve the signal to noise ratio. Figure 10 shows the Schottky signal of the bunched beam cooling system in the Fermilab Tevatron where the beam is in six bunches. The time between bunches contributes only to the noise of the system. Gating around the bunches dramatically improves the signal to noise ratio by a factor of the gating duty cycle.

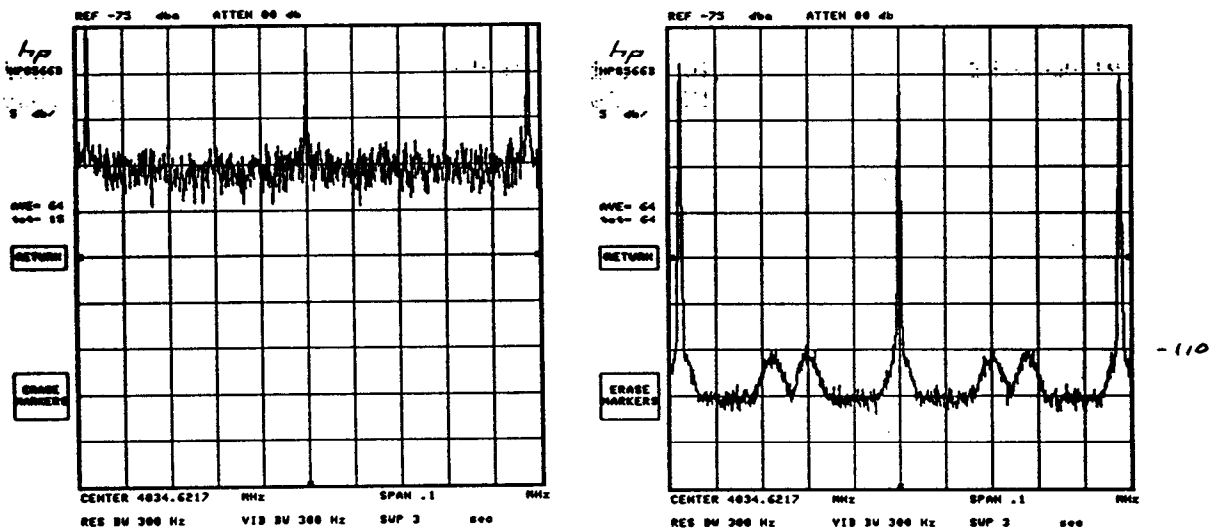

Figure 10. Effect of gating on signal to noise ratio. Left ungated bunched beam cooling signal. Right same signal with gating.

Digital Connection

A few words about signal to noise and dynamic range when working with digital circuits. The world of logic is predominantly base two. A factor of two is 6 dB in the voltage that an analog to digital converter (ADC) sees. Hence, an ADC of ten-bit resolution has a maximum dynamic range of 60 dB. If the analog input to the device has a SNR of 48 dB, the remaining two bits (12 dB) of the converter are meaningless. Matching the digitizing number of bits to the signal being digitized is important. Those bits are very expensive to create and manipulate. Don't buy more than you need. It's very popular today to boast about the number of bits a system can digitize, but that is not the significant side of the ADC.

Conclusions

Much of what has been presented is common sense. Careful inspection of system requirements and good engineering practice at the beginning of a project can result in better performance at a lower cost.

References

1. J. Marriner, Review of the Physics, Technology and Practice of Stochastic Beam Cooling, IEEE Particle Accelerator Conf. 1987, Vol. 3, pp 1383-1387.
2. R. J. Pasquinelli, Electro-Optical Technology Applied to Accelerator Beam Measurement and Control, IEEE Particle Accelerator Conf. 1993.
3. G. Jackson et al., A Test of Bunched Beam Stochastic Cooling the Fermilab Tevatron Collider, Proc. of 1991 IEEE Particle Accelerator Conf., pp. 1758-1760.
4. J. Hardy, High Frequency Circuit Design, Reston Publishing Co. 1979.
5. S. F. Adams, Microwave Theory and Applications, Prentice Hall , 1969.
6. BT&D corporation SOA 3200 data sheet, Wilmington, DE 19803.
7. Ortel corporation 5515B laser transmitter data sheet, Alhambre, CA. 91803.